

# NHD-24064WG-ATMI-VZ#

## Graphic Liquid Crystal Display Module

NHD- Newhaven Display  
24064- 240 x 64 pixels  
WG- Display Type: Graphic  
A- Model  
T- White LED Backlight  
M- STN- Blue (-)  
I- Transmissive, 6:00 view, Wide Temperature (-20°C ~ +70°C)  
VZ#- With Built-in Negative Voltage Supply  
**RoHS Compliant**

**Newhaven Display International, Inc.**

2511 Technology Drive, Suite 101

Elgin IL, 60124

Ph: 847-844-8795

Fax: 847-844-8796

[www.newhavendisplay.com](http://www.newhavendisplay.com)

[nhtech@newhavendisplay.com](mailto:nhtech@newhavendisplay.com)

[nhsales@newhavendisplay.com](mailto:nhsales@newhavendisplay.com)

## Document Revision History

Revision	Date	Description	Changed by
0	2/28/2008	Initial Release	-
1	4/9/2010	User guide reformat	BE
2	5/13/2010	Updated Backlight Supply Voltage and Current	MC
3	11/16/2010	Pin description update	AK
4	4/11/2011	Mechanical drawing updated	AK

## Functions and Features

- 240 x 64 pixels
- Built-in RA6963 controller
- +5.0V Power Supply
- 1/64 duty
- RoHS Compliant

# Mechanical Drawing

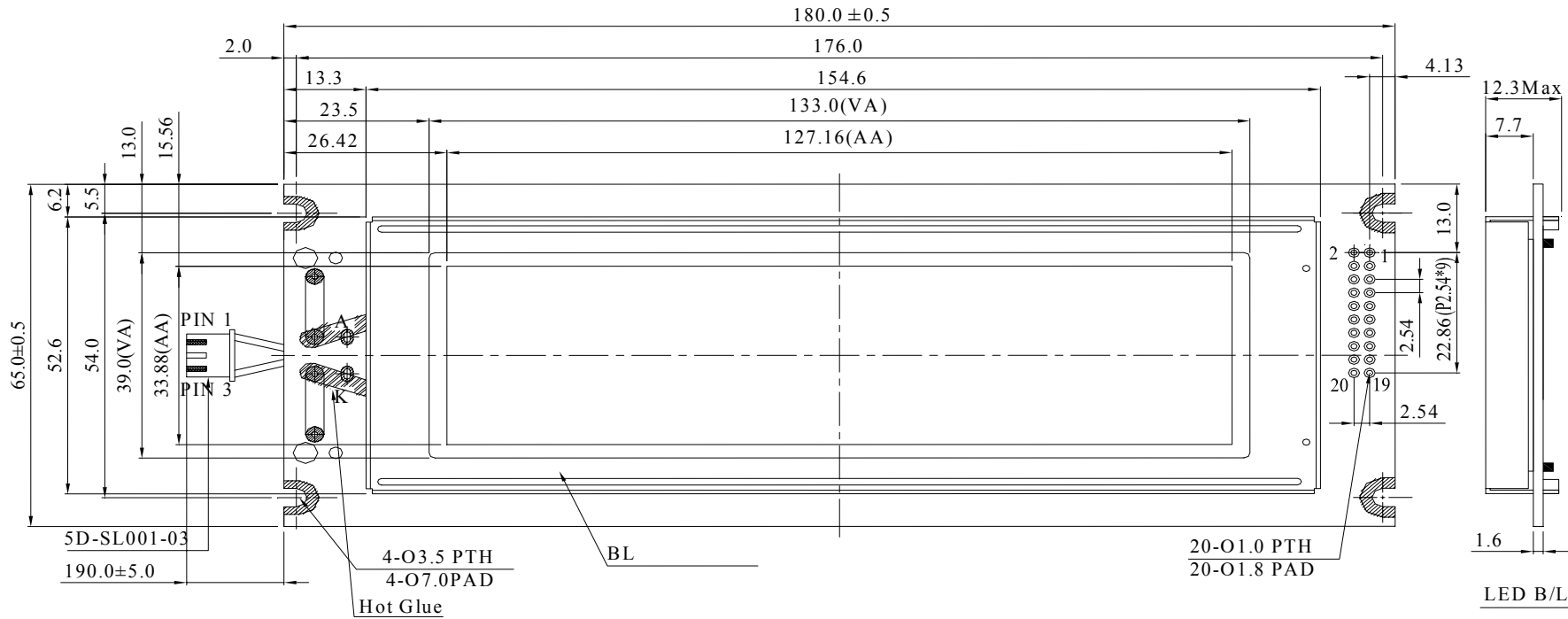

PIN NO.	SYMBOL
1	FGND
2	V <sub>ss</sub>
3	V <sub>dd</sub>
4	V <sub>o</sub>
5	WR
6	RD
7	CE
8	C/D
9	V <sub>ee</sub>
10	RESET
11	DB0
12	DB1
13	DB2
14	DB3
15	DB4
16	DB5
17	DB6
18	DB7
19	FS
20	NC

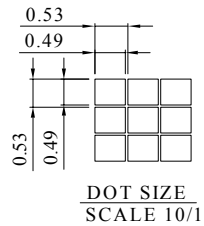
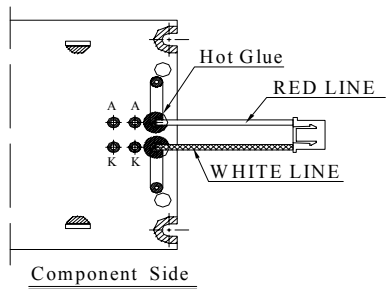

The non-specified tolerance of dimension is ±0.3 mm .

SCALE: 1/1	UNIT: mm	<b>Newhaven Display</b>
REV: 0	PAGE: 1/1	
APPROVE		MODEL NHD-24064WG-ATMI-VZ#
CHECK		TITLE
DRAW	Nina 01/23/06'	DWG NO.

## Pin Description and Wiring Diagram

Pin No.	Symbol	External Connection	Function Description
1	FGND	Power Supply	Frame Ground
2	VSS	Power Supply	Ground
3	VDD	Power Supply	Power supply for logic (+5.0V)
4	V0	Adj. Power Supply	Power supply for contrast (approx. -7V)
5	/WR	MPU	Active LOW Write signal
6	/RD	MPU	Active LOW Read signal
7	/CE	MPU	Active LOW chip enable
8	C/D	MPU	Register select signal C/D=0: DATA C/D=1: COMMAND
9	VEE	Power Supply	Negative voltage output (-10V)
10	RES	MPU	Active LOW reset signal
11~18	DB0~DB7	MPU	Bi-directional 8-bit data bus
19	FS	MPU	Font Select: 1=6x8 fonts, 0=8x8 fonts
20	NC	-	No Connect
A	LED+	Power Supply	Power supply for LED Backlight (+3.5V)
K	LED-	Power Supply	Ground for Backlight

**Recommended LCD connector:** 2.54mm pitch pins

**Backlight connector:** JST-XHP-3 **Mates with:** B 3B-XH-A

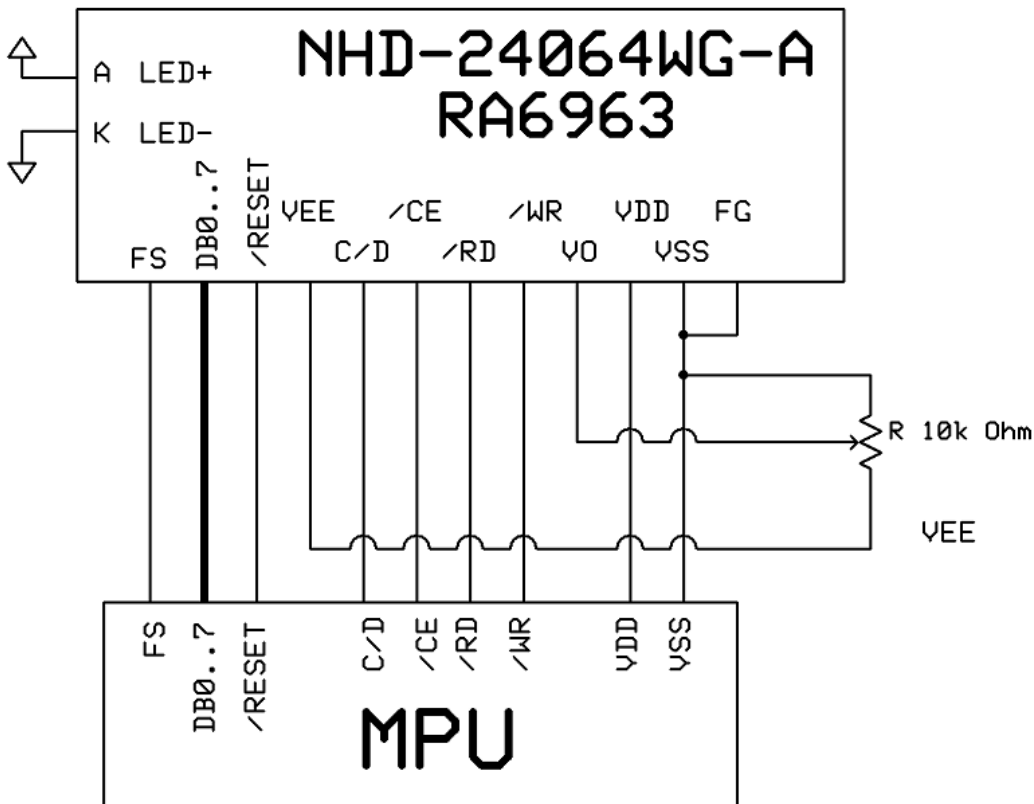

## Electrical Characteristics

Item	Symbol	Condition	Min.	Typ.	Max.	Unit
Operating Temperature Range	Top	Absolute Max	-20	-	+70	°C
Storage Temperature Range	Tst	Absolute Max	-30	-	+80	°C
Supply Voltage	VDD		4.75	5.0	5.25	V
Supply Current	IDD	VDD=5.0V	-	16	-	mA
Supply for LCD (contrast)	VDD-V0	Ta=25°	-	12.0	-	V
"H" Level input	VIH		2.2	-	VDD	V
"L" Level input	VIL		0	-	0.8	V
"H" Level output	VOH		2.4	-	VDD	V
"L" Level output	VOL		0	-	0.4	V
Backlight Supply Voltage	Vled	-	-	3.5	3.6	V
Backlight Supply Current	Iled	Vled=3.5V	80	100	128	mA
Backlight Lifetime	-	Iled=100mA	-	50,000	-	Hrs.

## Optical Characteristics

Item	Symbol	Condition	Min.	Typ.	Max.	Unit
Viewing Angle - Vertical (top)	AH	Cr ≥ 2	-	10	-	°
Viewing Angle- Vertical (bottom)	AH	Cr ≥ 2	-	105	-	°
Viewing Angle- Horizontal (left)	AV	Cr ≥ 2	-	30	-	°
Viewing Angle - Horizontal (right)	AV	Cr ≥ 2	-	30	-	°
Contrast Ratio	Cr		-	3	-	
Response Time (rise)	Tr	-	-	150	250	ms
Response Time (fall)	Tf	-	-	150	250	ms

## Controller Information

Built-in RA6963. Download specification at [http://www.newhavendisplay.com/app\\_notes/RA6963.pdf](http://www.newhavendisplay.com/app_notes/RA6963.pdf)

## Table of Commands

Command	Code	D1	D2	Function
<b>Registers Setting</b>	00100001	X address	Y address	Set cursor pointer
	00100010	Data	00h	Set Offset Register
	00100100	Low address	High address	Set Address pointer
<b>Set Control Word</b>	01000000	Low address	High address	Set Text Home Address
	01000001	Columns	00h	Set Text Area
	01000010	Low address	High address	Set Graphic Home Address
	01000011	Columns	00h	Set Graphic Area
<b>Mode Set</b>	1000X000	--	--	OR mode
	1000X001	--	--	EXOR mode
	1000X011	--	--	AND mode
	1000X100	--	--	Text Attribute mode
	10000XXX	--	--	Internal CG ROM mode
	10001XXX	--	--	External CG RAM mode
<b>Display Mode</b>	10010000	--	--	Display off
	1001XX10	--	--	Cursor on, blink off
	1001XX11	--	--	Cursor on, blink on
	100101XX	--	--	Text on, graphic off
	100110XX	--	--	Text off, graphic on
	100111XX	--	--	Text on, graphic on
<b>Cursor Pattern Select</b>	10100000	--	--	1-line cursor
	10100001	--	--	2-line cursor
	10100010	--	--	3-line cursor
	10100011	--	--	4-line cursor
	10100100	--	--	5-line cursor
	10100101	--	--	6-line cursor
	10100110	--	--	7-line cursor
	10100111	--	--	8-line cursor
<b>Data Read/Write</b>	11000000	Data	--	Data Write and Increment ADP
	11000001	--	--	Data Read and Increment ADP
	11000010	Data	--	Data Write and Decrement ADP
	11000011	--	--	Data Read and Decrement ADP
	11000100	Data	--	Data Write and Non-variable ADP
	11000101	--	--	Data Read and Non-variable ADP
<b>Data auto Read/Write</b>	10110000	--	--	Set Data Auto Write
	10110001	--	--	Set Data Auto Read
	10110010	--	--	Auto Reset
<b>Screen Peek</b>	11100000	--	--	Screen Peek
<b>Screen Copy</b>	11101000			Screen Copy
<b>Bit Set/Reset</b>	11110XXX	--	--	Bit Reset
	11111XXX	--	--	Bit Set
	1111X000	--	--	Bit 0 (LSB)
	1111X001	--	--	Bit 1
	1111X010	--	--	Bit 2
	1111X011	--	--	Bit 3
	1111X100	--	--	Bit 4
	1111X101	--	--	Bit 5
	1111X110	--	--	Bit 6
	1111X111	--	--	Bit 7 (MSB)
<b>Screen Reverse</b>	11010000	Data	--	Whole screen reverse

# Timing Characteristics

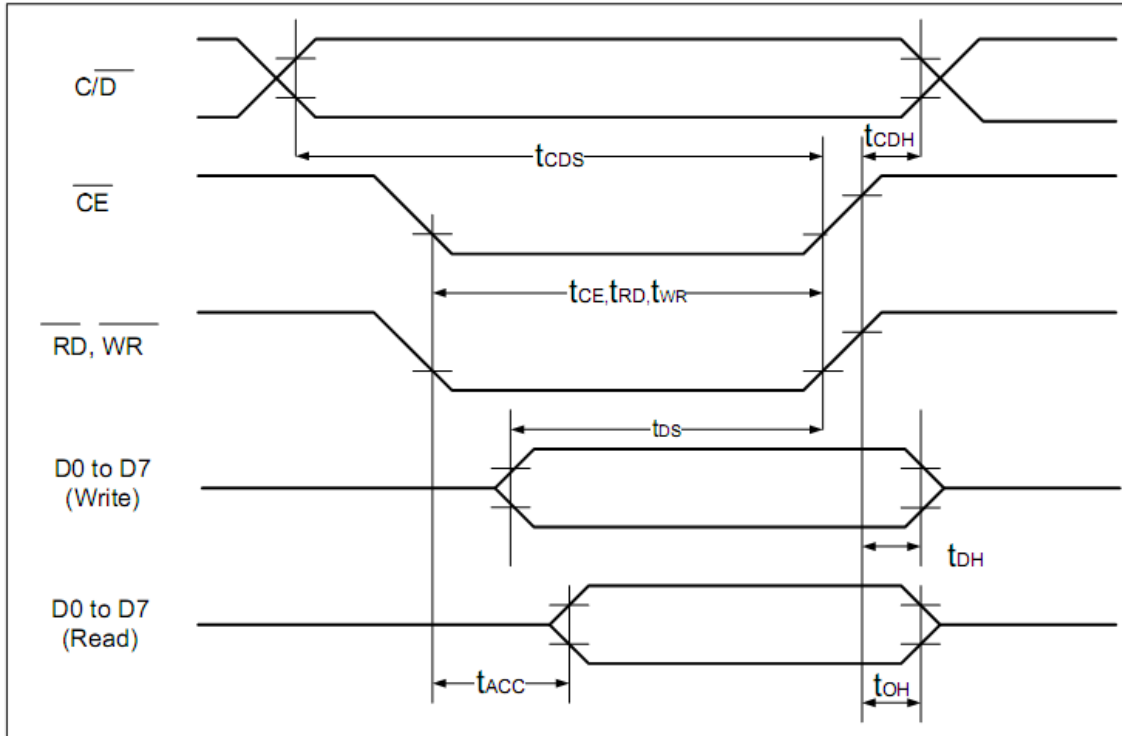

(  $V_{DD}=+5V\pm 5\%$ ,  $GND=0V$ ,  $T_a= -20$  to  $+70^\circ C$  )

Item	Symbol	Test Conditions	Min.	Max.	Unit
$\overline{C/D}$ Set Up Time	$t_{CDS}$	--	100	--	ns
$\overline{C/D}$ Hold Time	$t_{CDH}$	--	10	--	ns
$\overline{CE}$ , $\overline{RD}$ , $\overline{WR}$ Pulse Width	$t_{CE}$ , $t_{RD}$ , $t_{WR}$	--	80	--	ns
Data Set Up Time	$t_{DS}$	--	80	--	ns
Data Hold Time	$t_{DH}$	--	40	--	ns
Access Time	$t_{ACC}$	--	--	150	ns
Output Hold Time	$t_{OH}$	--	10	50	ns

## Example Initialization Program

```
void command(int A)
{
    P1 = A;
    ID = 1;           //Command
    CE = 0;
    WRT = 0;
    WRT = 1;
    CE = 1;
}

void data(int A)
{
    P1 = A;
    ID = 0;          //Data
    CE = 0;
    WRT = 0;
    WRT = 1;
    CE = 1;
}

void init()
{
    RST = 1;
    RDD = 1;
    F_S = 1;
    data(0x00);
    data(0x00);
    commnd(0x40);    //Set Text Home Address
    data(0x00);     //Low Address Columns
    data(0x40);     //High Address
    command(0x42);  //Set Graphic Home Address
    data(0x1E);    //Low Address Columns
    data(0x00);    //High Address
    command(0x41); //Set Text Area
    data(0x1E);    //Low Address Columns
    data(0x00);    //High Address
    command(0x43); //Set Graphic Areaa
    command(0x80); //Mode Set to 'OR' mode
}
```

## Quality Information

Test Item	Content of Test	Test Condition	Note
High Temperature storage	Endurance test applying the high storage temperature for a long time.	+80°C , 200hrs	2
Low Temperature storage	Endurance test applying the low storage temperature for a long time.	-30°C , 200hrs	1,2
High Temperature Operation	Endurance test applying the electric stress (voltage & current) and the high thermal stress for a long time.	+70°C 200hrs	2
Low Temperature Operation	Endurance test applying the electric stress (voltage & current) and the low thermal stress for a long time.	-20°C , 200hrs	1,2
High Temperature / Humidity Operation	Endurance test applying the electric stress (voltage & current) and the high thermal with high humidity stress for a long time.	+60°C , 90% RH , 96hrs	1,2
Thermal Shock resistance	Endurance test applying the electric stress (voltage & current) during a cycle of low and high thermal stress.	-20°C,30min -> 25°C,5min -> 70°C,30min = 1 cycle 10 cycles	
Vibration test	Endurance test applying vibration to simulate transportation and use.	10-55Hz , 15mm amplitude. 60 sec in each of 3 directions X,Y,Z For 15 minutes	3
Static electricity test	Endurance test applying electric static discharge.	VS=800V, RS=1.5kΩ, CS=100pF One time	

**Note 1:** No condensation to be observed.

**Note 2:** Conducted after 4 hours of storage at 25°C, 0%RH.

**Note 3:** Test performed on product itself, not inside a container.

## Precautions for using LCDs/LCMs

See Precautions at [www.newhavendisplay.com/specs/precautions.pdf](http://www.newhavendisplay.com/specs/precautions.pdf)

## Warranty Information and Terms & Conditions

[http://www.newhavendisplay.com/index.php?main\\_page=terms](http://www.newhavendisplay.com/index.php?main_page=terms)