

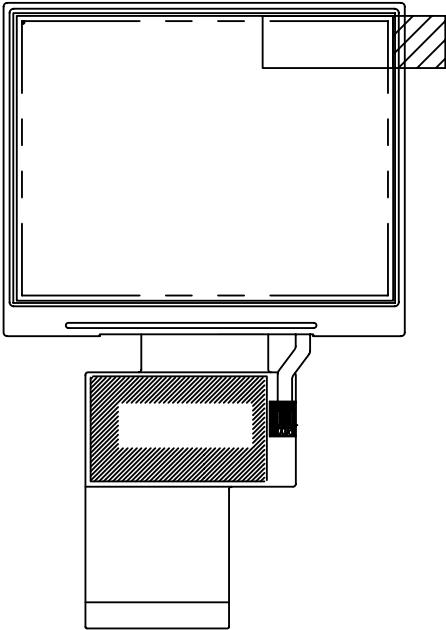

PRODUCT SPECIFICATION

HDA351-LV

QVGA, TFT COLOR GRAPHICS
LCD DISPLAY MODULE



HANTRONIX, INC. 10080 BUBB RD. CUPERTINO, CA 95014	Q.A.:	REV:	HDA351-LV	SHEET 1 OF 18
	ZW	1.0		DATE: 11/1/07

Application

This specification is applied to the 3.5 inch QVGA supported TFT-LCD module, and can display 262k colors. The module is designed for PMP, GPS application and other electronic products which require flat panel display of digital signal interface.

Features

- QVGA (320×240 pixels) resolution.
- Display in 262k colors
- Line inversion mode with stripe type.
- On-chip voltage generator
- SYNC mode is supported for digital RGB input data format.

General Specifications

Item	Specifications	Unit
Screen Size	3.5 (Diagonal)	inch
Display Format	320RGB(H)×240(V)	dot
Active Area	70.08(H)×52.56(V)	mm
Dot Pitch	0.073(H)×0.219(V)	mm
Pixel Configuration	RGB Vertical Stripe	-
Display Mode	TN Type Transmissive Mode Normally White	-
Surface Treatment	Anti-Glare	-
Viewing Direction	6 O'clock (The Gray Inversion will appear at this direction)	-
Outline Dimension	76.9(W)×63.9(H)×3.3(D)	mm
DC to DC circuit	Build-in	-
Weight	32	g

HANTRONIX, INC.
10080 BUBB RD.
CUPERTINO, CA 95014

Q.A.:
Z.W.

REV.:
1.0

HDA351-LV

SHEET 2 OF 18

DATE: 11/1/07

7. Absolute Maximum Ratings

7.1 Absolute Ratings of Environment

Item	Symbol	Value		Unit	Note
		Min.	Max.		
Storage Temperature	T _{ST}	-30	+80	°C	(1)
Operating Ambient Temperature	T _{OP}	-20	+70	°C	(1)

Note (1) Temperature and relative humidity range are shown in the figure below.

(a) 90%RH Max. (Ta ≤ 40°C).

(b) Wet-bulb temperature should be 39°C Max. (Ta > 40°C).

(c) No condensation.

7.2 Electrical Absolute Ratings

7.2.1 TFT-LCD Module

(Ta=25±2°C, GND=VSS=0V)

Item	Symbol	Value		Unit	Note
		Min.	Max.		
Digital Power Supply Voltage	VCC	VSS-0.3	5.0	V	-

7.2.2 Backlight Unit

(Ta=25±2°C)

Item	Symbol	Value		Unit	Note
		Min.	Max.		
Forward current	I _f	-	(30)	mA	(1)
Reverse voltage	V _r	-	(30)	V	(1)

Note (1) Permanent damage to the device may occur if maximum values are exceeded or reverse voltage is loaded.

HANTRONIX, INC. 10080 BUBB RD. CUPERTINO, CA 95014	Q.A.:	REV.:	HDA351-LV	SHEET 3 OF 18
	Z.W.	1.0		DATE: 11/1/07

Electrical Characteristics TFT-LCD Module

(Ta=25±2°C)

Item	Symbol	Value			Unit	Note
		Min.	Typ.	Max.		
Digital Power Supply Voltage	V _{CC}	2.5	3.3	3.6	V	-
Input High Threshold Voltage	V _{IH}	0.8V _{CC}	-	V _{CC}	V	-
Input Low Threshold Voltage	V _{IL}	0	-	0.2V _{CC}	V	-

(GND=VSS=0V)

Parameter	SYMBOL	Condition	Min	Typ	Max	Unit	Remarks
Digital Current	I _{VCC}	V _{CC} = 3.3V	-	15.6	22.0	mA	(1)
Total Power Consumption	PC	V _{CC} = 3.3V	-	51.48	72.6	mW	(1)

Note (1) The specified power consumption is under the conditions at V_{CC}=3.3V,
F_V=60Hz, whereas a power dissipation check pattern below is displayed.

Black Pattern / 0 Gray



Active Area

HANTRONIX, INC. 10080 BUBB RD. CUPERTINO, CA 95014	Q.A.:	REV.:	HDA351-LV	SHEET 4 OF 18
	Z.W.	1.0		DATE: 11/1/07

Backlight Unit

(Ta=25±2°C)

Item	Symbol	Value			Unit	Note
		Min.	Typ.	Max.		
LED Voltage	VL	-	(18.6)	-	V	(1)
LED Current	IL	-	(20)	-	mA	(1)
Power Consumption	P _{BL}	-	(372)	-	mW	(1)

Note (1) The driving design of backlight unit is dependent on serial consideration of six LEDs.

HANTRONIX, INC.
10080 BUBB RD.
CUPERTINO, CA 95014

Q.A.:
Z.W.

REV:
1.0

HDA351-LV

SHEET 5 OF 18

DATE: 11/1/07

9. Block Diagram

TFT-LCD Module with Backlight Unit

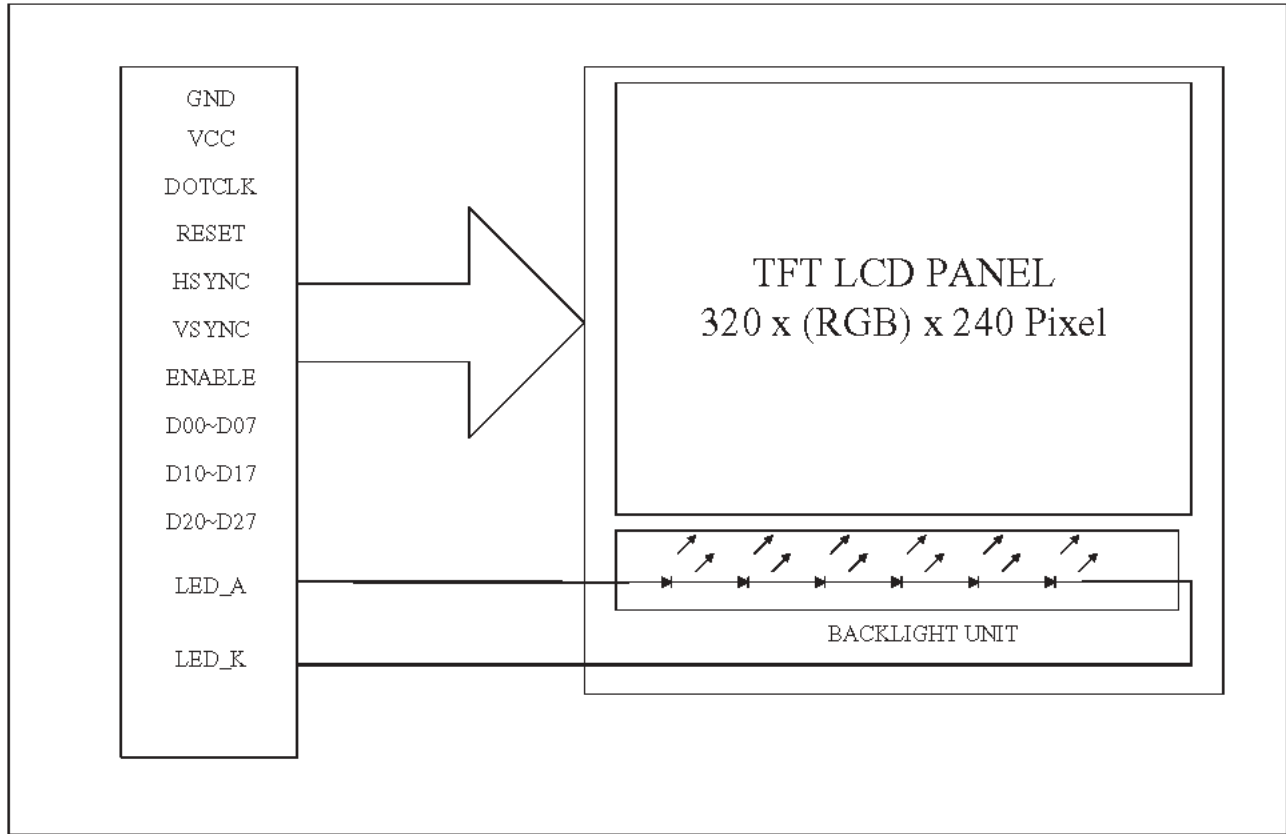

10. Input / Output Terminals Pin Assignment

10.1 TFT-LCD Module

Pin No.	Symbol	I/O	Description
1	LED_K	I	LED_cathode
2	LED_K	I	LED_cathode
3	LED_A	I	LED_anode
4	LED_A	I	LED_anode
5	NC	I	No connection
6	NC	I	No connection
7	POL	O	Test Pin, No connection
8	RESET	I	Reset
9	NC	I	No connection
10	NC	I	No connection
11	NC	I	No connection
12	D20	I	Blue data(LSB)
13	D21	I	Blue data
14	D22	I	Blue data
15	D23	I	Blue data
16	D24	I	Blue data
17	D25	I	Blue data
18	D26	I	Blue data
19	D27	I	Blue data(MSB)
20	D10	I	Green data(LSB)
21	D11	I	Green data
22	D12	I	Green data
23	D13	I	Green data
24	D14	I	Green data
25	D15	I	Green data
26	D16	I	Green data
27	D17	I	Green data(MSB)
28	D00	I	Red data(LSB)
29	D01	I	Red data
30	D02	I	Red data

HANTRONIX, INC.
10080 BUBB RD.
CUPERTINO, CA 95014

Q.A.:
Z.W.

REV.:
1.0

HDA351-LV

SHEET 7 OF 18

DATE: 11/1/07

Pin No.	Symbol	I/O	Description
31	D03	I	Red data
32	D04	I	Red data
33	D05	I	Red data
34	D06	I	Red data
35	D07	I	Red data(MSB)
36	HSYNC	I	Line synchronization signal.
37	VSYNC	I	Frame synchronization signal.
38	DOTCLK	I	Dot Colck signal
39	NC	I	No connection
40	NC	I	No connection
41	VCC	I	For system power supply.
42	VCC	I	For system power supply.
43	NC	I	No connection
44	NC	I	No connection
45	NC	I	No connection
46	NC	I	No connection
47	NC	I	No connection
48	NC	I	No connection
49	NC	I	No connection
50	NC	I	No connection
51	NC	I	No connection
52	NC	I	No connection
53	GND	I	Ground
54	GND	I	Ground

HANTRONIX, INC.
10080 BUBB RD.
CUPERTINO, CA 95014

Q.A.:
Z.W.

REV.:
1.0

HDA351-LV

SHEET 8 OF 18

DATE: 11/1/07

10.2 Color Data Input Assignment

The brightness of each primary color (red, green and blue) is based on the 8 bit gray scale data input for the color. The higher the binary input, the brighter the color. The table provides the assignment of color versus data input.

Color		Data Signal																							
		Red								Green								Blue							
		D07	D06	D05	D04	D03	D02	D01	D00	D17	D16	D15	D14	D13	D12	D11	D10	D27	D26	D25	D24	D23	D22	D21	D20
Basic Colors	Black	0	0	0	0	0	0	0	0	0	0	0	0	0	0	0	0	0	0	0	0	0	0	0	0
	Red	1	1	1	1	1	1	1	1	0	0	0	0	0	0	0	0	0	0	0	0	0	0	0	0
	Green	0	0	0	0	0	0	0	0	1	1	1	1	1	1	1	1	0	0	0	0	0	0	0	0
	Blue	0	0	0	0	0	0	0	0	0	0	0	0	0	0	0	0	1	1	1	1	1	1	1	1
	Cyan	0	0	0	0	0	0	0	0	1	1	1	1	1	1	1	1	1	1	1	1	1	1	1	1
	Magenta	1	1	1	1	1	1	1	1	0	0	0	0	0	0	0	0	1	1	1	1	1	1	1	1
	Yellow	1	1	1	1	1	1	1	1	1	1	1	1	1	1	1	1	0	0	0	0	0	0	0	0
	White	1	1	1	1	1	1	1	1	1	1	1	1	1	1	1	1	1	1	1	1	1	1	1	1
Gray Scale Of RED	Red(0) / Dark	0	0	0	0	0	0	0	0	0	0	0	0	0	0	0	0	0	0	0	0	0	0	0	0
	Red(1)	0	0	0	0	0	0	0	1	0	0	0	0	0	0	0	0	0	0	0	0	0	0	0	0
	Red(2)	0	0	0	0	0	0	1	0	0	0	0	0	0	0	0	0	0	0	0	0	0	0	0	0
	:	:	:	:	:	:	:	:	:	:	:	:	:	:	:	:	:	:	:	:	:	:	:	:	:
	:	:	:	:	:	:	:	:	:	:	:	:	:	:	:	:	:	:	:	:	:	:	:	:	:
	:	:	:	:	:	:	:	:	:	:	:	:	:	:	:	:	:	:	:	:	:	:	:	:	:
	Red(253)	1	1	1	1	1	1	0	1	0	0	0	0	0	0	0	0	0	0	0	0	0	0	0	0
Red(254)	1	1	1	1	1	1	1	0	0	0	0	0	0	0	0	0	0	0	0	0	0	0	0	0	
Red(255)	1	1	1	1	1	1	1	1	0	0	0	0	0	0	0	0	0	0	0	0	0	0	0	0	
Gray Scale Of Green	Green(0) / Dark	0	0	0	0	0	0	0	0	0	0	0	0	0	0	0	0	0	0	0	0	0	0	0	0
	Green(1)	0	0	0	0	0	0	0	0	0	0	0	0	0	0	1	0	0	0	0	0	0	0	0	0
	Green(2)	0	0	0	0	0	0	0	0	0	0	0	0	0	0	1	0	0	0	0	0	0	0	0	0
	:	:	:	:	:	:	:	:	:	:	:	:	:	:	:	:	:	:	:	:	:	:	:	:	:
	:	:	:	:	:	:	:	:	:	:	:	:	:	:	:	:	:	:	:	:	:	:	:	:	:
	:	:	:	:	:	:	:	:	:	:	:	:	:	:	:	:	:	:	:	:	:	:	:	:	:
	Green(253)	0	0	0	0	0	0	0	0	1	1	1	1	1	1	0	1	0	0	0	0	0	0	0	0
Green(254)	0	0	0	0	0	0	0	0	1	1	1	1	1	1	1	0	0	0	0	0	0	0	0	0	
Green(255)	0	0	0	0	0	0	0	0	1	1	1	1	1	1	1	1	0	0	0	0	0	0	0	0	
Gray Scale Of Blue	Blue(0) / Dark	0	0	0	0	0	0	0	0	0	0	0	0	0	0	0	0	0	0	0	0	0	0	0	0
	Blue(1)	0	0	0	0	0	0	0	0	0	0	0	0	0	0	0	0	0	0	0	0	0	0	0	1
	Blue(2)	0	0	0	0	0	0	0	0	0	0	0	0	0	0	0	0	0	0	0	0	0	0	1	0
	:	:	:	:	:	:	:	:	:	:	:	:	:	:	:	:	:	:	:	:	:	:	:	:	:
	:	:	:	:	:	:	:	:	:	:	:	:	:	:	:	:	:	:	:	:	:	:	:	:	:
	:	:	:	:	:	:	:	:	:	:	:	:	:	:	:	:	:	:	:	:	:	:	:	:	:
	Blue(253)	0	0	0	0	0	0	0	0	0	0	0	0	0	0	0	0	1	1	1	1	1	1	0	1
Blue(254)	0	0	0	0	0	0	0	0	0	0	0	0	0	0	0	0	1	1	1	1	1	1	1	0	
Blue(255)	0	0	0	0	0	0	0	0	0	0	0	0	0	0	0	0	1	1	1	1	1	1	1	1	

11. Interface Timing

11.1 Input Signal Characteristics

11.1.1 Digital Parallel RGB Interface (960×240 resolution)

Characteristics	Symbol	Min.	Typ.	Max.	Unit	
		24 bit	24 bit	24 bit		
DOTCLK Frequency	fDOTCLK	-	6.5	10	MHz	
DOTCLK Period	tDOTCLK	100	154	-	ns	
Horizontal Frequency (Line)	fH	-	14.9	22.35	KHz	
Vertical Frequency (Refresh)	fV	-	60	90	Hz	
Horizontal Back Porch	tHBP	-	68	-	tDOTCLK	
Horizontal Front Porch	tHFP	-	20	-	tDOTCLK	
Horizontal Data Start Point	tHBP	-	68	-	tDOTCLK	
Horizontal Blanking Period	tHBP + tHFP	-	88	-	tDOTCLK	
Horizontal Display Area	HDISP	-	320	-	tDOTCLK	
Horizontal Cycle	Hcycle	-	408	450	tDOTCLK	
Vertical Back Porch	tVBP	-	18	-	Lines	
Vertical Front Porch	tVFP	-	4	-	Lines	
Vertical Data Start Point	tVBP	-	18	-	Lines	
Vertical Blanking Period	tVBP + tVFP	-	22	-	Lines	
Vertical Display Area	NTSC	VDISP	-	240	-	Lines
	PAL		280(PALM=0)			
			288(PALM=1)			
Vertical Cycle	NTSC	Vcycle	-	262	350	Lines
	PAL		313			

HANTRONIX, INC.
10080 BUBB RD.
CUPERTINO, CA 95014

Q.A.:
Z.W.

REV.:
1.0

HDA351-LV

SHEET 10 OF 18

DATE: 11/1/07

11.2 Waveform

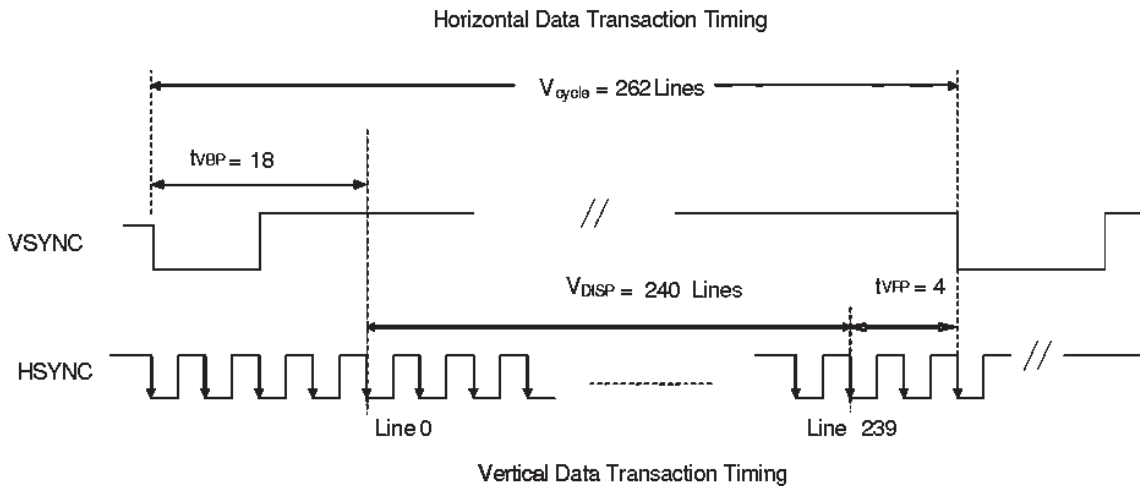
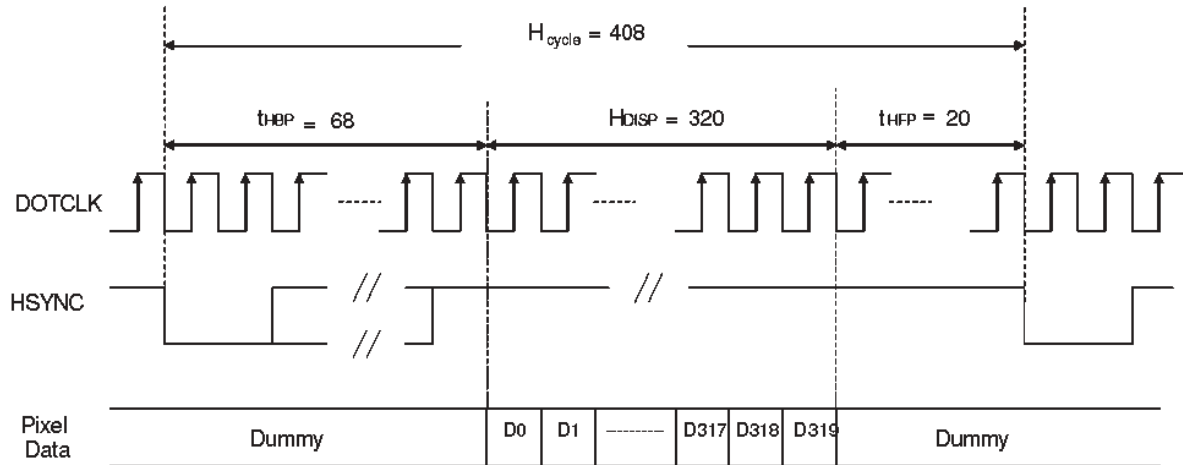

Data Transaction Timing in Parallel RGB (24 bit) Interface (SYNC Mode)

11.3 Power On / Off Sequence

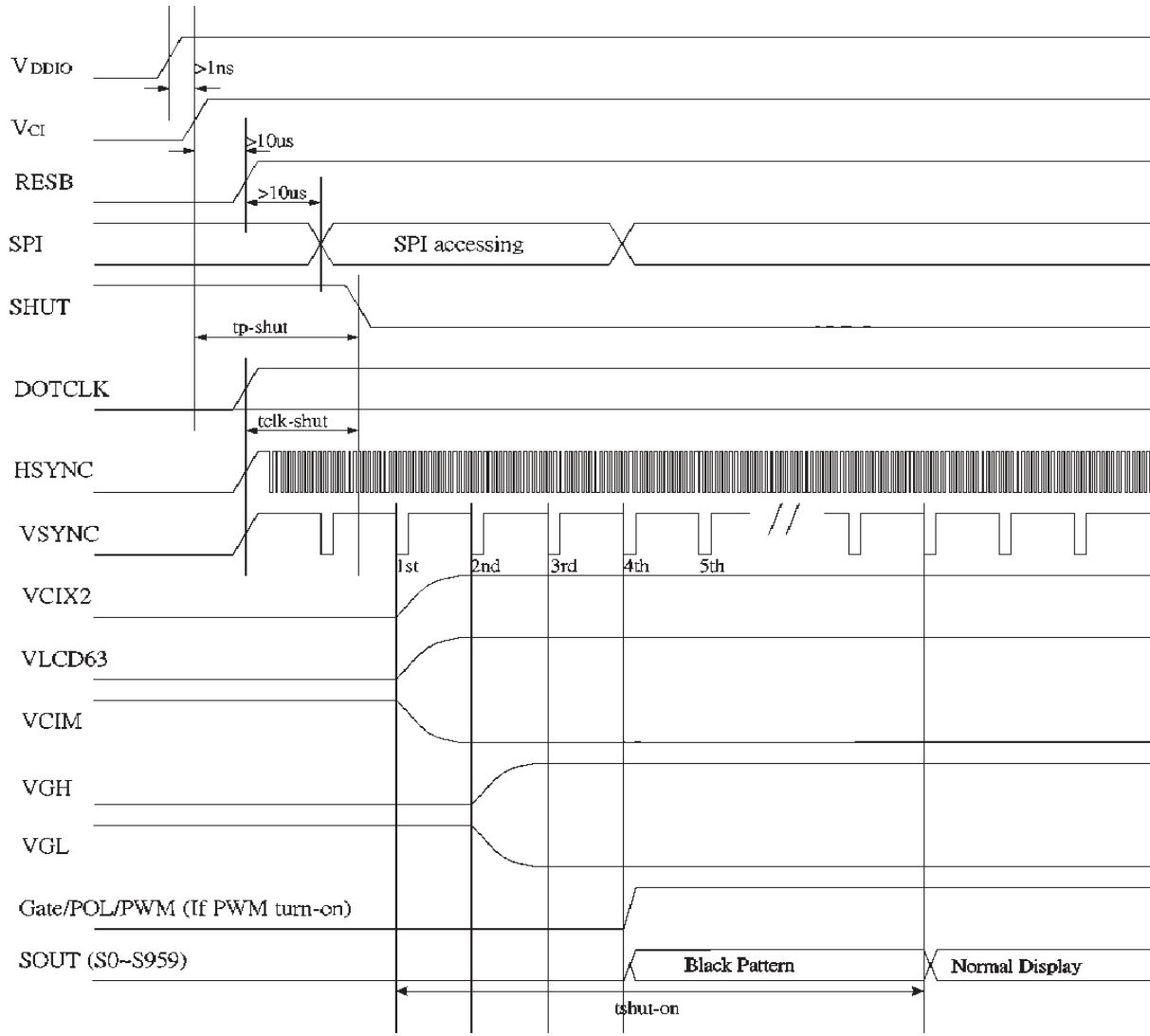

Power Up Sequence

Characteristics	Symbol	Min.	Typ.	Max.	Unit
VCI/ VDDIO on to falling edge of SHUT	tp-shut	1	-	-	us
DOTCLK to falling edge of SHUT	tclk-shut (Note1)	1	-	-	clk
Falling edge of SHUT to display start - 1 line: 408 clk - 1 frame: 262 line - DOTCLK = 6.5MHz	tshut-on (Note2)	-	10	-	frame

Power Up Sequence

Note1: It is necessary to input DOTCLK before the falling edge of SHUT.
Note2: Display starts at 10th falling edge of VSTNC after the falling edge of SHUT. The display starts at the falling edge of VSYNC which is determined by BLT[1:0] of R04h.

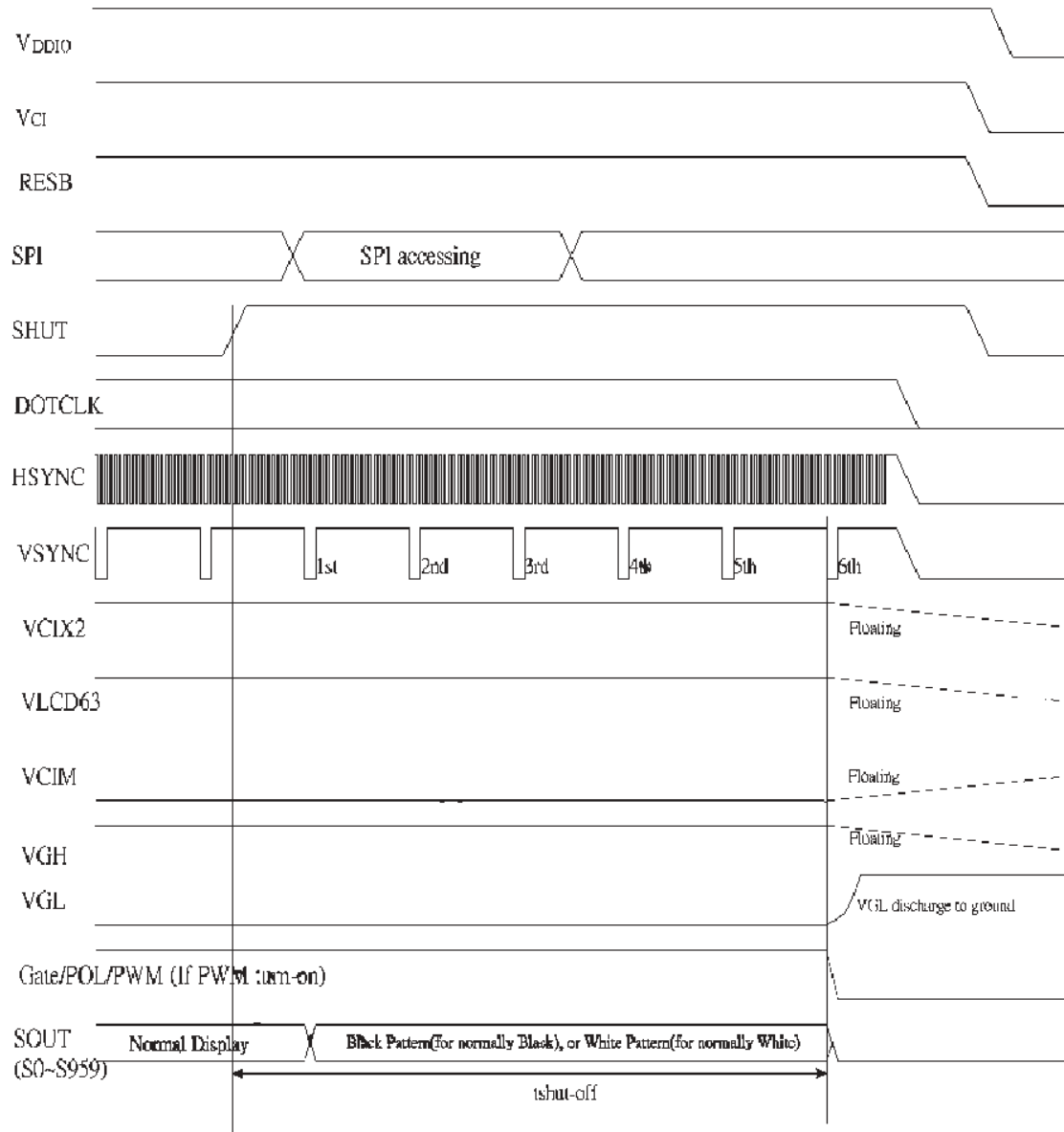

Power Down Sequence

Characteristics	Symbol	Min.	Typ.	Max.	Unit
Rising edge of SHUT to display off - 1 line: 408 clk - 1 frame: 262 line - DOTCLK = 6.5MHz	tshut-off	-	-	6	frame

Note: DOTCLK must be maintained at least 6 frames after the rising edge of SHUT.
 Display become off at the 6nd falling edge of VSTNC after the falling edge of SHUT.
 If RESET signal is necessary for power down, provide it after the 6-frames-cycle of the SHUT period.

Power Down Sequence

Optical Characteristics

The optical characteristics should be measured in a dark environment (≤ 1 lux) or equivalent state with the methods shown in Note (4).

Item		Symbol	Conditions	Min.	Typ.	Max.	Unit	Note
Contrast Ratio		CR	$\theta_x=0^\circ, \theta_y=0^\circ$ Viewing Normal Angle	300	450	-	-	(2)
Response Time		T_{R+T_F}		-	50	-	ms	(3)
Luminance(Center)		Y		300	350	-	cd/m ²	(4)
Brightness uniformity		BUNI		80	-	-	%	(5)
Color Chromaticity	Red	Rx		0.510	(0.560)	0.610	-	(1),(4)
		Ry	0.370	(0.420)	0.470	-		
	Green	Gx	0.220	(0.270)	0.320	-		
		Gy	0.620	(0.670)	0.720	-		
	Blue	Bx	0.090	(0.140)	0.190	-		
		By	0.030	(0.080)	0.130	-		
	White	Wx	0.210	(0.260)	0.310	-		
		Wy	0.300	(0.350)	0.400	-		
Viewing Angle	Horizontal	θ_{x+}	CR \geq 10	55	70	-	deg.	
		θ_{x-}		55	70	-		
	Vertical	θ_{y+}		40	65	-		
		θ_{y-}		50	70	-		

HANTRONIX, INC.
10080 BUBB RD.
CUPERTINO, CA 95014

Q.A.:
Z.W.

REV.:
1.0

HDA351-LV

SHEET 14 OF 18

DATE: 11/1/07

Note (1) Definition of Viewing Angle (θ_x , θ_y):

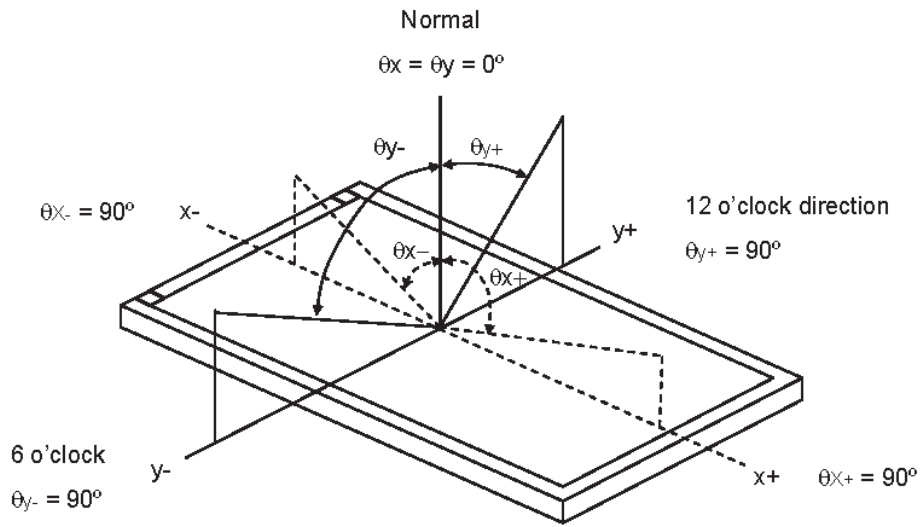

Note (2) Definition of Contrast Ratio (CR):

Measured at the center point of panel

$$\text{Contrast Ratio (CR)} = L_{255} / L_0$$

L_{255} : Luminance of gray level 255

L_0 : Luminance of gray level 0.

Note (3) Definition of Response Time (T_R , T_F):

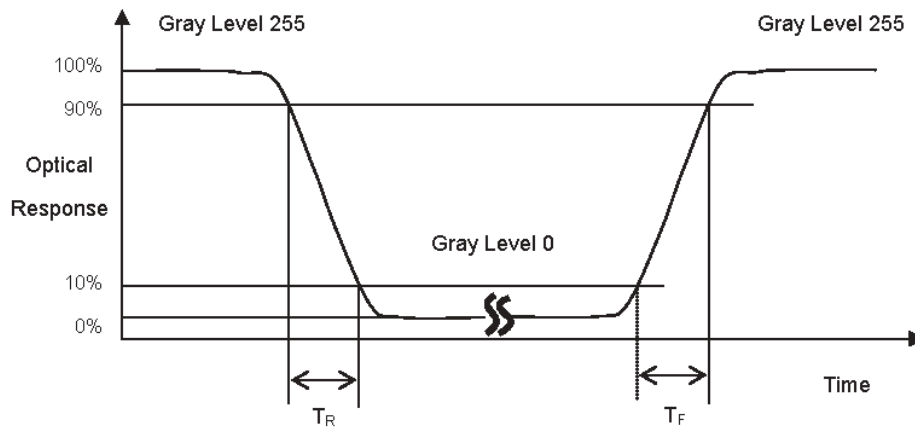

HANTRONIX, INC.
 10080 BUBB RD.
 CUPERTINO, CA 95014

Q.A.:
 Z.W.

REV.:
 1.0

HDA351-LV

SHEET 15 OF 18

DATE: 11/1/07

Note (4) Measurement Set-Up:

The LCD module should be stabilized at a given temperature for 30 minutes to avoid abrupt temperature change during measuring. In order to stabilize the luminance, the measurement should be executed after lighting Backlight for 30 minutes in a windless room.

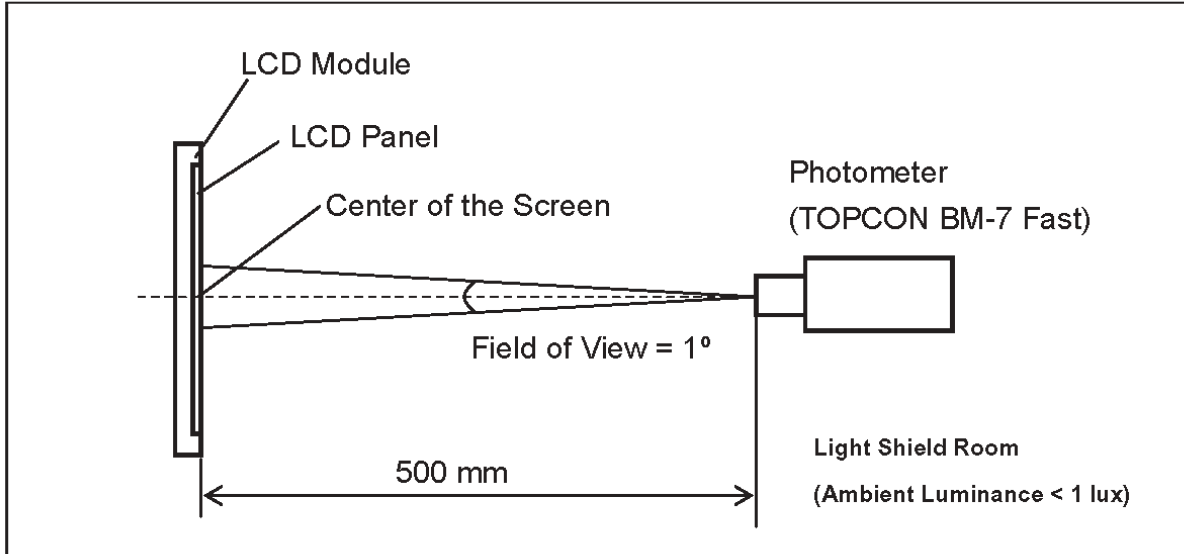

Note (5) Definition of brightness uniformity

$$\text{Brightness uniformity} = (\text{Min Luminance of 9 points}) / (\text{Max Luminance of 9 points}) \times 100\%$$

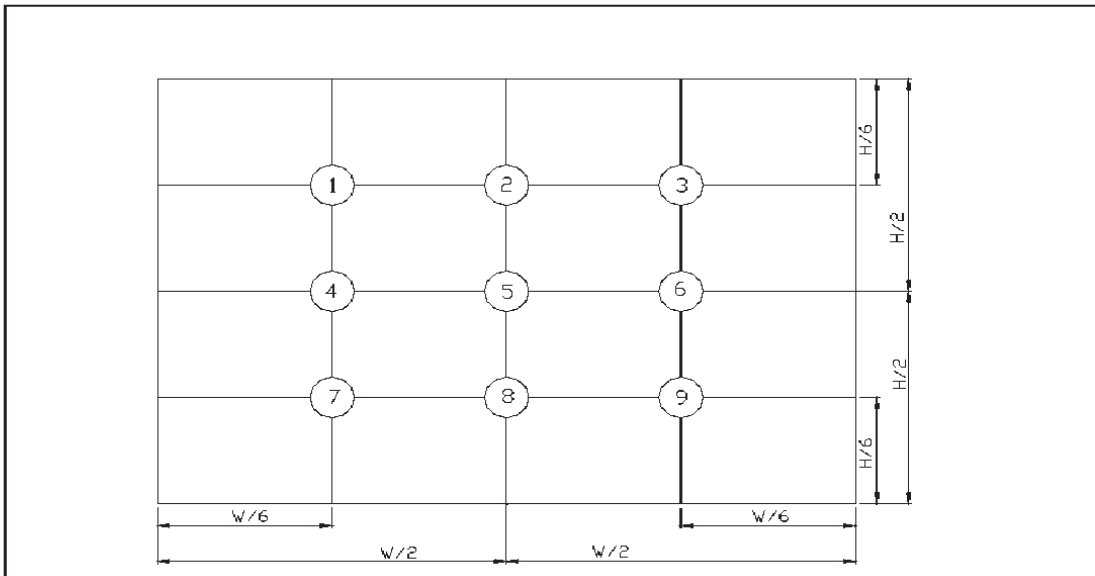

HANTRONIX, INC. 10080 BUBB RD. CUPERTINO, CA 95014	Q.A.:	REV.:	HDA351-LV	SHEET 16 OF 18
	Z.W.	1.0		DATE: 11/1/07

13. Reliability Test

No.	Test Items	Test Condition	Remark
1	High Temperature Storage Test	T _a = 80°C 240 hours	-
2	Low Temperature Storage Test	T _a = -30°C 240 hours	-
3	High Temperature Operation Test	T _a = 70°C 240 hours	-
4	Low Temperature Operation Test	T _a = -20°C 240 hours	-
5	High Temperature and High Humidity Operation Test	T _a =60°C 90%RH 240 hours	-
6	Electro Static Discharge Test (non-operating)	-Panel Surface/Top Case : 150pF, 330Ω Air: ±15kV, Contact: ±8kV	-
7	Mechanical Shock Test (non-operating)	Half sine wave, 80G, 11ms 3 times shock of each six surfaces	-
8	Vibration Test (non-operating)	Sine wave, 10 ~ 55 ~ 10Hz, 3 axis, 2 hours/axis	-
9	Thermal Shock Test (non-operating)	-20°C (30min) ~ 70°C (30min), 100 cycles	-
10	Drop Test(with Carton)	Height: 80cm 1 corner, 3 edges, 6 surfaces	-

HANTRONIX, INC. 10080 BUBB RD. CUPERTINO, CA 95014	Q.A.:	REV.:	HDA351-LV	SHEET 17 OF 18
	Z.W.	1.0		DATE: 11/1/07

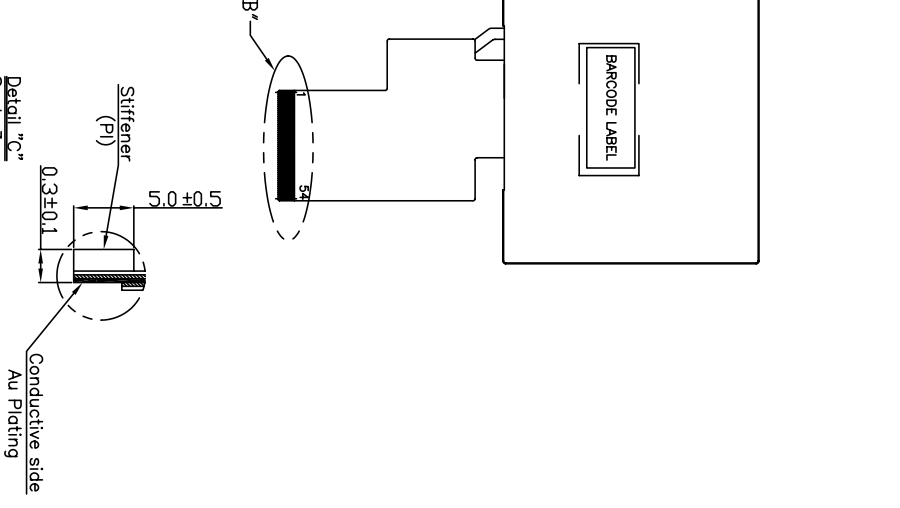
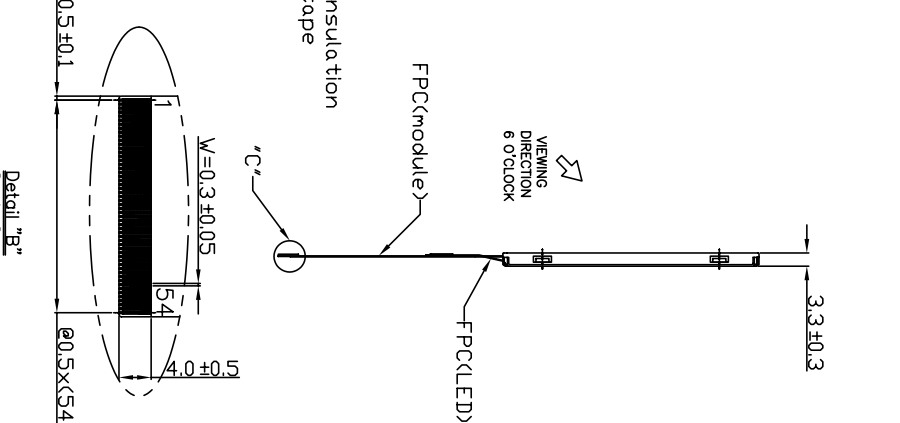
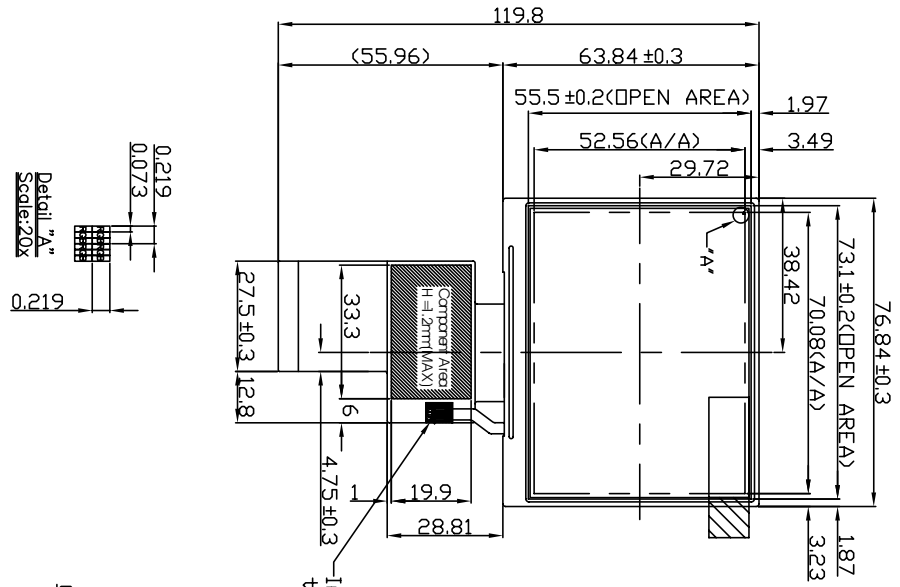

HANTRONIX, INC.
10080 BUBB RD.
CUPERTINO, CA 95014

Q.A.:
Z.W.

REV.:
1.0

HDA351-LV

SHEET 18 OF 18

DATE: 11/1/07